

Design of filters for rainwater purification.

Carlos Alberto Peña Arriaga, Elizabeth Lopez Carmona, Wendy Aracely Duran
Guarneros, Emmanuel Garcia Guillen y Jonny Carmona Reyes

*Technological University of Tlaxcala located in el Carmen Xalpatlahuaya s/n,
90513 Huamantla, Tlaxcala.*

Abstract:

Currently there is an urgent social and environmental need to ensure the supply of drinking water to the population, in this case the Technological University of Tlaxcala (UTT), within the university there is a well from which drinking water is obtained and looking for an alternative to supply drinking water to the university community, this project is proposed which consists of the use and filtration of rainwater.

This project is about purifying rainwater for human consumption and consists of a series of filters. Among which we have the paper cartridge filter that keeps solids, particles and other impurities out of liquid solutions, suspensions and other liquids, as well as an activated carbon filter and a zeolite filter. The zeolite filter will provide purer water and the activated carbon filter will remove the taste and odor from the water.

Now we know that the treatment of water for human consumption is a complex process that introduces chemical elements to the water, the best known is chlorination and the most important is the filtration that consists of obtaining drinking water through a system of cartridge filters, activated carbon and zeolite, among others.

1. Introduction

When we talk about water filtration we refer to a purification method where a water treatment process removes pollutants that were dragged by it when it precipitated, some of the pollutants present in rainwater are: lead, sulfur dioxide nitrogen dioxides among other pollutants present. (Crittenden 2012) for this reason leaking becomes a major challenge.

The purification of rainwater is intended to prevent damage to health and mitigate disasters, raising awareness of the shortage of vital liquid, as it has encouraged the search for alternatives to obtain it.

The benefits of rainwater go beyond use for human consumption and also nourish the conservation of forests and wetlands by reducing pressure on aquifers, Wells and even the construction of new DAMS for urban supply.

We propose a design of an alternative rainwater filtration system within the technological university of tlaxcala to ensure that it is potable and has no impact on the health of the university community.

This project is designed to use rainwater, through a filtering alternative and collect information according to the guidelines of the official Mexican standard nom-127-ssa1-2021, water for human use and consumption. Permissible water quality limits (gob 2022)

Within the technological university of tlaxcala we talk about water filtration, we refer to a purification method where, through a water treatment process, contaminants that were carried by it when precipitating are eliminated, Some of the contaminants present in rainwater are: lead, sulfur dioxide, nitrogen dioxide, among others. contaminants present. (Crittenden 2012)

Within the Technological University of Tlaxcala there is a purifying plant which is supplied by a well. located within it, upon seeing the water shortages that society faces and in search of a new alternative to have drinking water, a rainwater filtration project was proposed which was mainly used as an alternative for water supply, in addition to helping us ensure that society is not exposed to any disease from consuming wáter contaminated from the network that the University has, by some type of bacteria or harmful particles, taking advantage of the rainwater.

(Canepa , Barreneche , & Maldonado, 2004)

1.2. Methodology:

Nom-127-ssa1-2021 establishes the permissible quality limits that water for human use and consumption must meet within those mentioned: it must not have as source of supply treated wastewater, as well as a ph level ranging between 6.5 and 8.5.

A series of activities described in the diagram below will be carried out to obtain the desired research results. (federacion, 2022) NOM-127-SSA1-2021

. (Federacion, 2022)



Fig.1. Diagram-methodology (source: authors' creation)

1.2.1 Water Filtration

Filtration is the process of removing suspended solids from water by passing it through different types of filters. Some contaminants pose a threat to human health and filtration is one of the oldest and simplest methods of removal. (c, 2023)



Fig.2. cartridge filter(NESCWest Virginia University)

Filtration is usually a combination of physical and chemical processes, mechanical filtration removes some particles by trapping them between the grains of the filter medium (sand). Adhesion is also a process by which suspended particles stick to the surface of the filter grains or material previously deposited. (filtering, 2023)

This step is important in the treatment and purification of rainwater since it removes suspended particles using a filter media, in the treatment of rainwater there are different media that help to obtain better water quality, for example: (ramirez quiros, 2015)

Supply: these systems are regularly composed of paper filters, activated carbon or sand filters, in turn can be accompanied by a chemical treatment such as chlorination and ion exchange to remove minerals that are dissolved.

During the planning of our research, a survey was made to the student community of the industrial maintenance course in which, in order to be able to quantify quickly and effectively, we were asked for a sample of 99 students in a population of 132 with a margin of error of 5%.

In which the following formula was used (QuestionPro, s.f.):						
Sample	Size	=	Z²	*	(p)	c²

Where:

Z = confidence level (95% or 99%)

P =.5

C = error margin (.04 = + 4)

Based on our project they were asked if the water purifying filter would be a good alternative in which 54.5% said it would be a good alternative as shown in FIG 3.

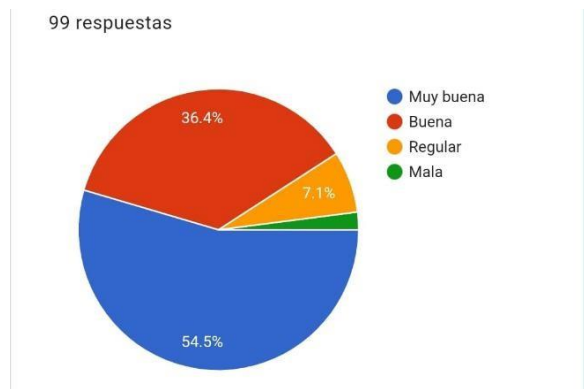

Fig 3 Grafico de Respuesta 1 (Referencia: propia)

As in the study carried out, the student community was asked if they were aware of the consequences of consuming water in poor condition to which nearly 50% of the community responded, not having knowledge about the consequences as we can see in fig.4.

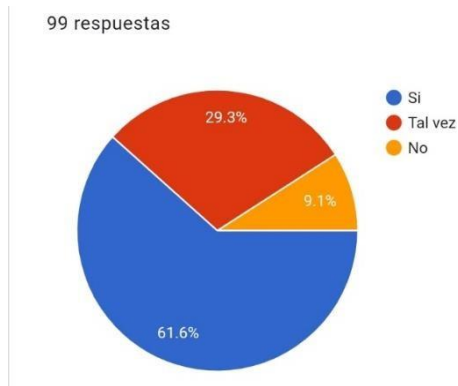

Fig.4 Grafico de la respuesta 2(Referencia: propia)

They were also asked if they were aware of the benefits of purifying water and we observed that most people have the basic knowledge of water purification and its benefits which is good as it plays an important role in our lives. Fig.5

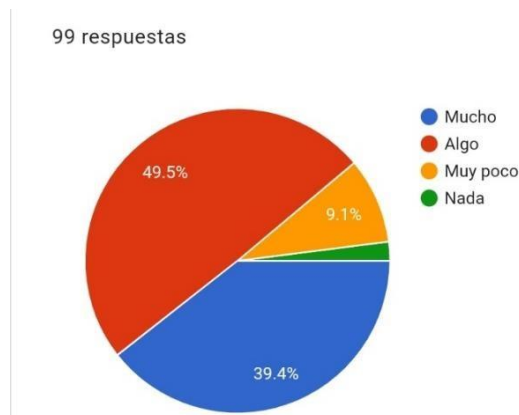

Fig.5 Grafico de la respuesta 3(Referencia: elaboración propia)

Finally and presenting the designed prototype we asked them if they would use a filter like ours to purify water, to see if our proposal was viable and we could observe that it is since more than 60% say they would use it and the other 30% answer that maybe as we can see in our graph number 6.

Once we obtained the results of our survey and seeing the feasibility of the project we began to make the prototype with the required materials. This involves a series of filters which are described below.

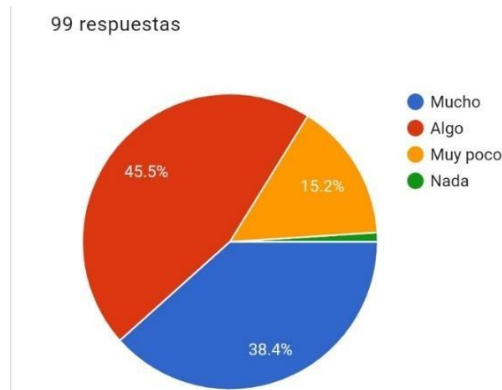

Fig 5 Grafico de la respuesta 4(Fuente:Propia)

1.2.2. Zeolite filter:

This filter mainly softens the water because due to its properties absorbs calcium and magnesium among other elements more, once the water passes through the filter we will result in softer water and neutralized.

Zeolite slightly reduces the acidity of the water. Less product is required than silica sand due to its porosity and density. It has a greater surface area and porosity. Produces greater clarity in the filtered water. Zeolite is the most durable filter media (more than 5 years). Zeolite increases flow in equipment with multimedia and gravity and pressure systems compared to sand filters. Para este filtro se utiliza una armazón de filtros para Rotoplas, donde se sustituye el cartón por piedra de zeolita. (Evans, 2023)



Fig.7 Filtro de papel (Fuente: Propia)

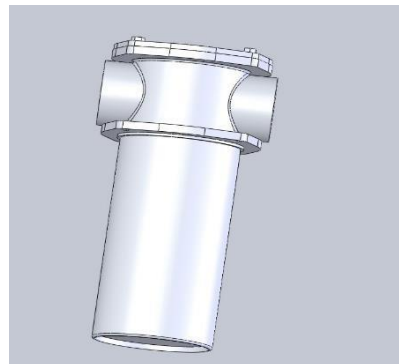

Fig.8 Diseño de carcasa de filtro(Fuente: Propia)

1.2.3. Activated carbon filter:

The activated carbon filter is of Paramount importance within a filtering system as it removes impurities and contaminants as well as smaller particles, after the water passes through a filter like this it will get clear, odorless water.

Some more of its applications are: removal of odors, flavors, residual chlorine and organic matter from process water when required. Preparation of flavourless, odourless, chlorine-free water for use in the soft drink and food industries. Removal of chlorine and organic matter from feed water for demineralization equipment. Final treatment of sewage and industrial waste water to remove organic matter and odours. The filter used in this case has to: ensure through its precision a certain degree of cleanliness of the liquid to be treated, ensure through reliability uninterrupted and undisturbed operation of the entire system (medrano, 2006).

In this step we chose to add an activated carbon filter to the system. The following image shows how it works: (j.f, 2023)

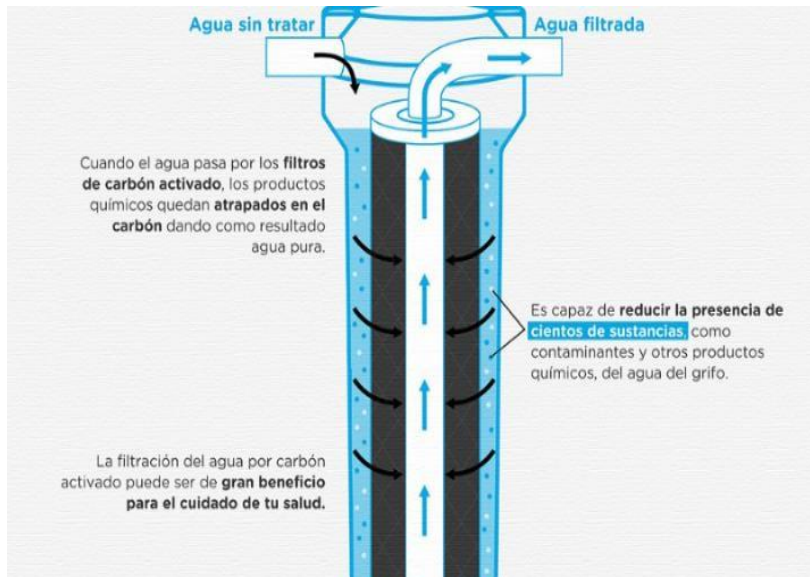

Fig.9. Funcionamiento de filtro de carbón activado (Fuente: Filtración del agua por carbón activado)

1.2.3. Case to place filters:

A wooden cabinet was built to place the filters this cabinet has measures of 60 cm high by 50 cm wide and a bottom of 30 cm there was also made the connection of the pipes to finish with the physical part of the project.

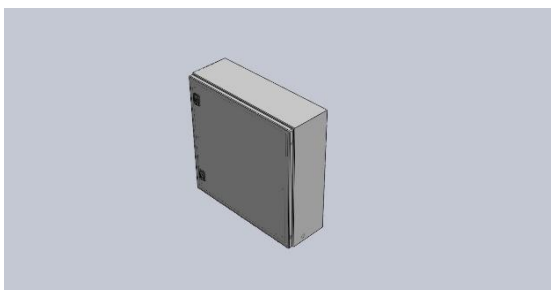

Fig.10.Gabinete(Fuente: Propia)

All the pipe used to connect the filtration system is PVC with a diameter of 3/4 inch.

This was followed by ph studies of the filtered water to confirm the quality of the water, initially a ph level was obtained between 5 and 5.5 with which we determined that the water was too acidic, after the filtering process the test results were acceptable, since our study gave a ph level between 7.5 and 8, so it was determined that the water is neutral and slightly alkaline,

The salinity is acceptable as well as the color and flavor of the water since the activated carbon was very effective in the filtering process.

Conclusions

A prototype of a water filtration system has been designed and its quality is close to nom-127-ssa.

It is known that water filtration systems are important to have quality drinking water, this contributes to the human being does not have repercussions on their health by drinking contaminated water, and this alternative filtration is a very good idea to support the supply of drinking water, since if filtered rainwater can reduce the overexploitation of Wells or water deposits

The filtering system (purifier) evaluated in this research resulted in water fit for human consumption from rainwater with some harmful characteristics. The materials used are easy to use.

References:

- C, N. (10 de Agosto de 2023). *AGUA*. Obtenido de <https://files.conagua.gob.mx/conagua/mapas/SGAPDS-1-15-Libro36.pdf>
- Canepa , L., Barreneche , A., & Maldonado, V. (2004). *Tratamiento de agua para consumo humano* . Centro panamericano.
- Evans. (10 de Septiembre de 2023). Obtenido de https://evans.com.mx/media/manuales/ZEO_FT3.pdf
- Federacion. (05 de mayo de 2022). *SEGOB*. Obtenido de https://www.dof.gob.mx/nota_detalle.php?codigo=5650705&fecha=02/05/2022#gsc.tab=0
- Filtracion*. (22 de Agosto de 2023). Obtenido de <https://www.aqua-free.com/es/revista/un-vistazo-sobre-los-diferentes-tipos-de-filtracion>
- J.F, M. (13 de mayo de 2023). *Ecofiltro*. Obtenido de <https://ecofiltro.mx/blogs/news/para-que-sirve-el-filtro-de-carbon-activado#:~:text=Los%20filtros%20de%20Carb%C3%B3n%20Activado,hasta%20el%2095%20%25%20del%20cloro>.
- QuestionPro*. (s.f.). Obtenido de Calculadora de Muestras : [https://www.questionpro.com/es/calculadora-de-muestra.html#:~:text=Tama%C3%B1o%20de%20Muestra%203D%20Z%20*%20\(confianza%20\(%2095%25%20o%2099%25\)\)](https://www.questionpro.com/es/calculadora-de-muestra.html#:~:text=Tama%C3%B1o%20de%20Muestra%203D%20Z%20*%20(confianza%20(%2095%25%20o%2099%25)))
- Ramirez Quiros, F. (15 de Agosto de 2015). *Tratamiento de Desinfección del agua potable*. Obtenido de <https://www.fundacioncanal.com/canaleduca/wp-content/uploads/2015/08/Tratamiento-de-desinfeccion-del-agua-potable2.pdf>