

# ENHANCEMENT OF WIDEBAND CODE DIVISION MULTIPLE ACCESS NETWORK BASED ON FUZZY LOGIC INTELLIGENT CONTROLLER

D. Okorie<sup>a</sup>, B.Okeke<sup>b</sup>, Chinenye C. Opara<sup>d</sup>

*a.,b,c. Department of Information Technology, School of Computing and Information Technology, Federal University of Technology Owerri,*

---

## Abstract

Wideband Code Division Multiple Access is an optimized version for 2.5G and 2.5G GPRS. WCDMA can be said to be a 3G wireless mobile technology basically used for fast data transfer transactions in form of voice, data applications to internet surfing and other several online operations. WCDMA was designed primarily intelligent systems and others smart phones due to its high speed internet accessibility. In recent times, network has drastically reduced in its efficiencies due to increase in the number of intelligent systems and smart phone users, this has posed a great challenge to internet providers on the quality of service they render to their subscribers especially on the rate of call drops. Based on the stated observations, this work is geared towards providing an improved congestion mitigation approach by employing fuzzy logic technology to better the quality of services to subscribers. The optimization was stimulated using a Matlab fuzzy tool, the result showed a great deal improvement on the network congestion. This was done using Fuzzy optimization intelligent system which monitors incoming cell by accepting mean bit rate, reject mean burst rate, monitor and constantly adjust its queue capacity whenever network instability or variation is experienced and feeding the quality of service at every end of the service. The system intelligently and constantly re-adjusts until an optimum quality of service is attended.

*Keywords:* Fuzzy Tool, Wideband Code Division Multiple Access, 3G wireless Mobile Technology

---

## 1. Introduction

In recent times, lots of work are been done based on devices connectivity and interaction on the platform of internet of things (IoT) network. According to the analyst firm's predictions, about 8.4 Billion device connection were to be in use in 2017, most of which perform sensing and monitoring tasks using wireless sensor networks (WSNs), in the addition to this, there has been high intensive increase in the number of mobile communication device users all these account for the degradation in the performance of WCDMA network which is experienced as congestion in form of call drops, poor connectivity, package drop, long delay, low throughput, high energy consumption etc.

### 1.1. Data Mining Concepts

The aim of this research work centre on enhancing the QoS of WCDMA network by deploying intelligent fuzzy logic model which monitors and regulate incoming data in a base station. The specific objective includes developing a fuzzy logic algorithm using a fuzzy matlab tool; the stimulated fuzzy algorithm was deployed in a virtual environment at varied network traffic environment, the efficiency of throughput was great.

## 2. Literature Review

### 2.1. Conceptual Frame Work

Wideband Code Division Multiple Access (WCDMA) can be said to be a multiple access technology normally used in the Universal Mobile Telecommunication Service (UMTS) which provides 3rd generation services as mobile communications demand increases. The user information bits are broaden all over a wider bandwidth thereby multiplying the user data bit with quasi-random bits as known as chips derived from CDMA spreading codes which supports very high bit rates (up to 2 Mbps). The main parameters of WCDMA are presented below: ( Popova L.N., 2009).

- i. Wide Code Division Multiple Access uses direct Sequence Spread Spectrum (DSSS) technique to spread the user information over a wider bandwidth.
- ii. WCDMA also uses 5MHz carrier bandwidth.
- iii. Its chip rate is about 3.84 Mbps.
- iv. WCDMA also supports bandwidth on demand this implies variable data rates for different users.
- v. WCDMA also permits both Frequency Division Duplex (FDD) as well as Time Division Duplex (TDD) methods.

#### A. Base Station Subsystem

Base Station Subsystem is made of the Base Transceiver Station (BTS) and the Base Station Controller (BSC). This base station subsystem communicates together across a specified Abis interface, thereby ensuring operation between components made by different suppliers. The Base Transceiver Station inbuilt the radio transceivers which define a cell as well handle the radio link protocols with the Mobile Station. In Developed areas, a large number of BTSs deployed. The need for a BTS is essentially ruggedness, portability, reliability and minimum cost.

Base Station Controller manages and controls the radio resources for different BTS. They also handle frequency hopping, handovers and radio channel setup. The BSC links the mobile and the Mobile service Switching Center (MSC) together. It also translates the 13kbps voice channel over the radio link to the standard 64 kbps channel used by the Public Switched Telephone Network.

#### B. Network Congestion

Network congestion is a key challenge in resource-constrained networks, particularly those with limited bandwidth to accommodate high-volume data transmission which causes unfavorable quality of service, including effects such as packet loss and low throughput. There have been complaints of the quality of Service delivered to service providers in the country continuously over the last 5 years. The Service providers had to pay fines billed on them by NCC in 2013 and 2014 there by agreeing to delivering poor service. The National Association of Telecommunications Subscribers (NATCOMS) requested that Subscribers be paid directly for the poor service quality delivered but the NCC said through their spokesperson that this could not be done because there is no provision for this in the National Communications Act.(Phet G. 2018).

#### C. The Quality of Service (QoS)

The quality of service provided to the subscribers has been a great challenge to the service providers as there have been complaints within the country continuously over the last 5 years. In 2013 and 2014, NCC billed the

service providers to pay a fine due to the poor quality of service they provide. The National Association of Telecommunications Subscribers (NATCOMS) requested that Subscribers be paid directly for the poor service quality delivered but the NCC said through their spokesperson that this could not be done because there is no provision for this in the National Communications Act (Oje A.A 2017). Quality of service is defined In the ITU-T Recommendation E.800 1993, as the collective service performance, mainly determined by the degree of satisfaction of a subscriber of a particular network. In Nigeria telecom industries, the voice service quality is measured by Grade of Service (GoS) and Quality of Service (QoS) (Isabona, 2014).

This simply implies that QoS is the ability of a particular network to offer a service within certain quality. The QoS is associated with different number of parameters. Mostly used parameters include:

1. Availability of up and download link
2. Bit errors numbers
3. Latency (delay in the network)
4. Jitter

Each of these parameters is dependent on the service provided. For instance, the voice service and video service requires a very low latency but might tolerate bit error rate whereas the generic data applications tolerates negligible or no bit error but latency is not critical.

## 2.2. Emperical Frame Work

Ozovehe and Usman (2015) researched on “Performance Analysis of GSM network in Minna metropolis of Nigeria”, they compared various KPIs performance using NCC QoS rating. Most of these KPIs includes Call Drop Rate (CDR), Call Setup Success rate (CSSR), Call Completion Success rate (CCSR), Traffic channel (TCH) Congestion Rate etc and drew a conclusion that KPIs can be employed to grade networks with multiple radio source management functions such as paging network access, congestion, Call drop, Handover, and power control and also they were of the view that KPIs that are used to measure Network Performance. Atenaga and Isabona (2014) studied the “compromise between network performance and end user satisfaction over UMTS Radio interface in Asaba Delta state. The assessment and analysis which compared network performance and subscriber’s satisfaction using selected KPIs CDR, HOSR, CSSR, ESA and NRR. The author considered the five clustered ranging from 1-5 in his analysis. A drive test to conduct measurements in the frequency cellular network of study. The subscriber’s satisfaction was assessed by estimating the total number calls blocked probability (Pblock) well as the number calls drop probability (Pdrop) data. In conclusion, the authors deduced that end user satisfaction rate decreases as each of the QoS based network performance indicators decreases and verse versa and that the QoS provided by network operators have one to one relationship with the end user satisfaction

### 3. Analysis and Design

#### 3.1. Analysis of the Proposed System

Enhanced WCDMA network was analyzed using architectural diagram shown in figure 3.1

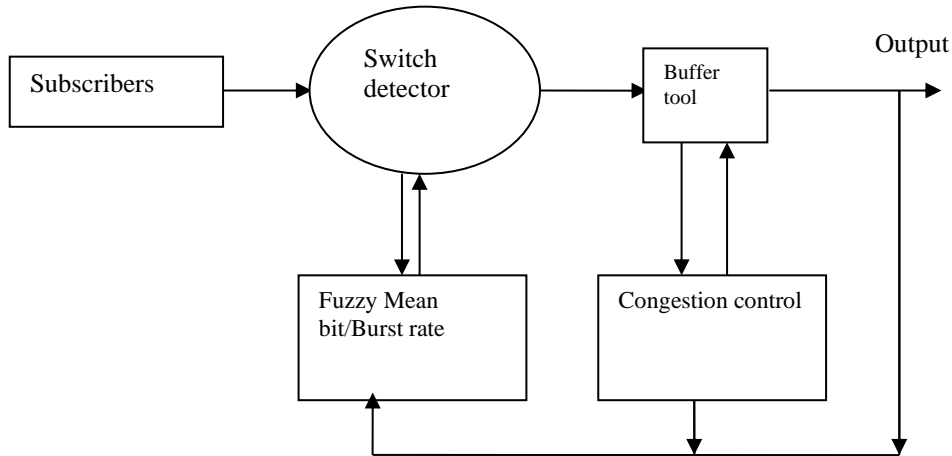

Figure 3.1: Architectural design of the proposed system

*The proposed fuzzy component:*

**Switch detector:** This component carries out two major functions, to detect in coming cells into the system as well as imposing the decision of the fuzzy mean bit/burst rate to either drop or pass cells which are in compliance with the system decisions.

**Fuzzy mean Bit/Burst rate:** this part of the component carries out the system decision by checking cells which are in compliances with the fuzzy mean bit rate and burst rate. Thereby instructing the switch detector to either pass or drop such cell.

**Buffer tool:** this component is a temporal storage scheme which holds cells and directs them on queues to avoid creating bottle neck congestion for the incoming cells.

**Congestion control:** this component constantly monitors and controls the queue length and rate of change in the queue. Thereby determining the situation of the network and feeding back to the fuzzy mean bit/burst rate to implement more strict compliance measure for a better quality of service to the end-users

### 3.2. Simulation Design

A stimulated analysis was carried out in a virtual environment to determine the efficiency of the proposed system in handling congestion at varied network node. The data in Table 4.1 were input into the virtual environment the result shown as in figure 2.

Table 4.1 Shows the Simulated Congestion Load Environments

<b>Traffic load environments</b>	Mean_Bit_Rate	Mean_Burst_L	Network_S	NCC QoS threshold	Performance
Network variations 1	1.36	1.31	0.562	0.357	0.791
Network variations 2	1.47	1.42	0.27	0.856	0.99
Network variations 3	1.47	1.42	0.27	-0.678	0.50
Network variations 4	1.32	1.33	0.876	0.456	0.855
Network variations 5	1.32	1.33	0.876	-0.144	0.51

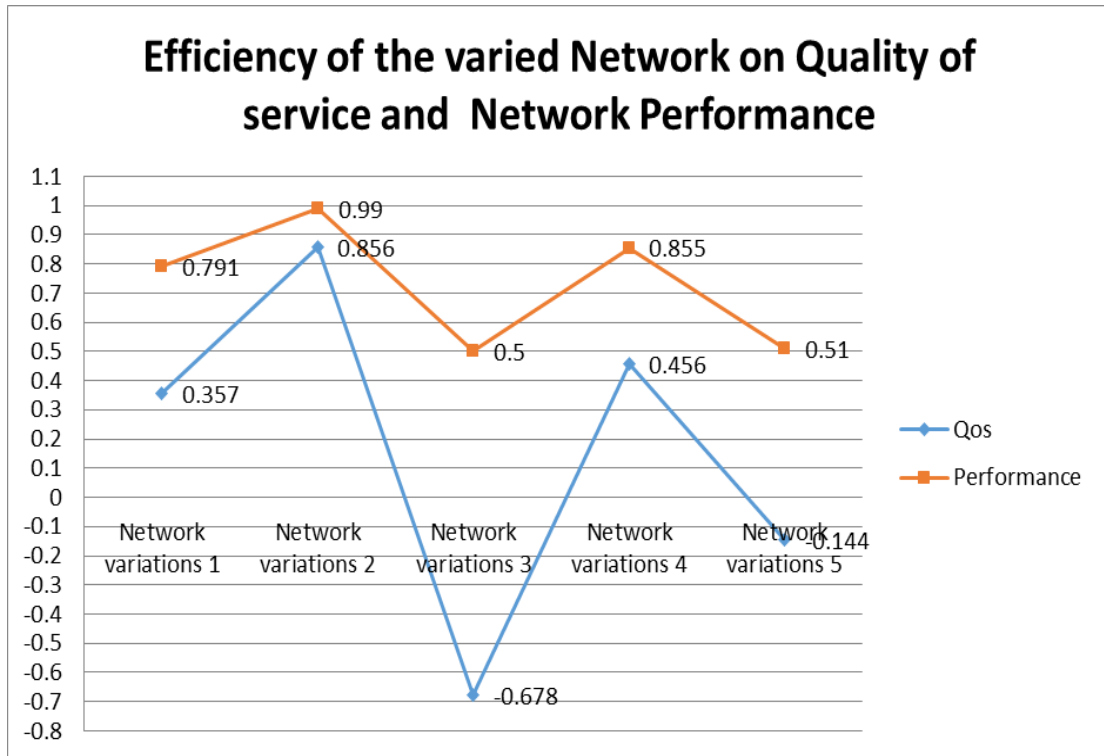

Figure 3.2

#### 4. Results and Discussion

The work was designed to mitigate network congestion issues as well as improving the quality of service rendered to its subscribers.

##### 4.1 Discussion

The above figure 3.2 presents the output result of the virtual environment stimulated using a fuzzy algorithm on a fuzzy tool. The result shows a great deal on the fuzzy logic intelligent algorithm handling the mitigation of network congestion in the virtual environment. From Figure 2, at network variation 3 it was observed that the quality of service dropped to negative from 0.8 to -0.6 and the system throughput dropped from 1 to 0.5. At this state the system will adjust the incoming calls in the buffer and prevent congestion and interference in the system. As the QoS drops to -0.678 the congestion controller sent signal to the fuzzy mean bit/burst rate, the fuzzy mean bit/burst rate compress the queue capacity by enforcing more strict compliance terms this will free the entrance for more connections. The network will drop from 100% to 50%. The proposed system is efficient to handle such variations.

The proposed system ensures that the congestion is free and improves QoS for network utility. The proposed system is very efficient and intelligent to adjust the queue capacity in the based state whenever there is network instability or variation.

#### 4.2 Summary of Findings

The system constantly checks incoming cells to ensure they met the NUC compliance threshold since most cells comes with bit error, jitter, latency etc then decides either to pass or drop the cells. It also monitors the buffer to ensure congestion free network. One outstanding check for the validity of this design is the flexibility of the system been able to re-adjust at any worse network case to produce a feasible quality of service for its users as such the system is designed to produce at worst case of quality of service 50% efficiency. The system checks the incoming calls ensures they meet the

#### 5. Conclusion

As various concepts and principles have been employed in imitating network congestion, the application of fuzzy logic intelligence system provides more and better features in outputting a feasible quality of service for internet service providers.

#### References

- Atenuga, M, and Isabona J, (2014). The compromise between Network Performance and End-User Satisfaction over UMTS Radio Interface: An Empirical Investigation. International Journal of Advance Research in physical Science (IJARPS) 1, (8),9-18.
- ETSI TS 102 250-1 v2.2.1 (2011-04) Speech and multi Transmission Quality (STQ); QoS aspects for popular services in mobile networks; part 1: Assessment of Quality of Service
- International Engineering Consortium, (2008). Cellular Communicators". <http://www.iec.org>
- Isabona, J.,Ekpenyong M., (2015). End- User satisfaction Assessment Approach for efficient network performance monitoring in wireless communication systems. African Journal of Computing & ICT. (Afr J Comp & ICT) 8, (1).
- ITU-T Rec. E.800, Aug. (1993) Terms and Definitions Related to Quality of Service and Network Performance Including Dependability.
- Joseph, Isabona& Kingsley Obahiagbon, (2014). A Practical Optimisation Method to Improve QoS and GoS-Based Key Performance Indicators In GSM Network Cell Cluster Environment. International Journal of Wireless & Mobile Networks (IJWMN) 6, (5).
- Jraifi abdelouahed, (2012). A theoretical prediction of users in WCDMA interference. Journal of theoretical and Applied Information Technology 35, (2)
- Kadoglu, R., Dalveren Y., and Kara A., (2015). Quality of service assessment: a case study on performance benchmarking of cellular network operators in Turkey. Turkish Journal of Electrical Engineering & Computer sciences (Turk J Elec & Comp Sci) 548-559
- Kiyea, C. (2014). Evaluation and Comparative Analysis of the Quality of Service of GSM and CDMA cellular Network in Zaria. Dept of Mathematics, Faculty of Science, Ahmadu Bello University Zaria Nigeria.

Kuboye, B.M., Alese B.K. and Fajuyigbe O., (2009). Congestion analysis on the Nigerian Global System for Mobile Communication (GSM) network. *Pacific journal of Science and Technology*.10, (1), 262-271

Leonid, Reznik (1997). *A Basic Structure of Fuzzy logic Controller*. Victoria University of Technology, Melbourne Australia.

Nosiri Onyebuchi Chikezie, Onyenwe Ezinne Maureen, Ekwueme Emmanuel Uchenna (2019) Fuzzy Logic Implementation for Enhanced WCDMA Network Using Selected KPIs. *Advances in science, Technology and Engineering Systems Journal* Vol. 4, No. 1, 114-124

Ononiwu Gordon, AkinwoleBukola,Agubor Cosmos, Onojo James (2016) Performance Evaluation of Major Mobile Network Operators in Owerri Metropolis of Nigeria. *International Journal of Emerging Technologies in Computational and Applied Sciences (IJETCAS)* 06-13.

Ozovehe, A and Usman A.U., (2015). Performance Analysis of GSM Networks in Minna metropolis of Nigeria. *Nigeria Journal of Technology (NIJOTECH)*. 34, (2), 359-367.

Popova, Larissa N, (2009). Quality of Service oriented Traffic Engineering Methods for multi-Service Cellular Networks. *Technical University of Denmark, Lyngby*.

Ugwu, Chidiebere, and Bale Dennis L.T., (2012). *An Intelligent Fuzzy logic System for traffic Congestion*.

Ugwuoke, F.N., Okafor K.C., Onwusuru I.M., Udeze C.C (2014). Using Software Engineering Approach in Mitigating QoS Challenges in Mobile Communication Networks in Nigeria” *Computing, Information Systems, Development Informatics & Allied Research Journal*. 5, (1), 131-148